

SURVEYOR'S NARRATIVE:

THE PURPOSE OF THIS SURVEY IS TO DO A BOUNDARY LINE ADJUSTMENT TO SEPARATE TWO HOMES SO THE WESTERLY HOME CAN BE FINANCED FOR A PENDING SALE. TAX LOT 100 WILL BE REDUCED TO 1.00 ACRE AND CONTAIN A MANUFACTURED HOME.

I SUBDIVIDED THE SE 1/4 OF SECTION 9 IN CS#05-148-C FOR CHOWNING AND RETRACED THAT SURVEY TO ESTABLISH THE CORNERS OF THESE TWO TAX LOTS.

TAX LOT 100 IS DESCRIBED AS TRACT 4 IN A DEED TO WARREN N. AND JUANITA M. ROSS ON INSTRUMENT # 2008-5410682 UMATILLA COUNTY DEED RECORDS AND IS DESCRIBED AS THE E 1/2 OF THE NE 1/4 OF THE SW 1/4 OF THE SE 1/4 OF SECTION 9, T 4 N, R 28 E, W.M., UMATILLA COUNTY, OREGON. EXCEPTING THEREFROM ANY PORTION LYING WITHIN THE COUNTY ROAD RIGHT-OF-WAY.

TAX LOT 200 IS DESCRIBED AS TRACT 5 IN THE SAME DEED AS TAX LOT 100 AND IS DESCRIBED AS THE W 1/2 OF THE NE 1/4 OF THE SW 1/4 OF THE SE 1/4 OF SAID SECTION 9. EXCEPTING THEREFROM THE WEST 178 FEET OF THE NORTH 490 FEET. ALSO EXCEPTING THEREFROM ANY PORTION LYING WITHIN THE COUNTY ROAD RIGHT-OF-WAY.

BOTH OF THESE TAX LOTS WILL SHARE A WELL, PUMP HOUSE, AND A SEPTIC TANK AND DRAIN FIELD WHICH ARE ALL LOCATED ON REVISED TAX LOT 200. THE APPROXIMATE LOCATION OF THE SEPTIC TANK, DRAIN FIELD, SEWER LINE, AND WATER LINE ARE SHOWN ON THE MAP. SAID SEWER LINE, WATER LINE AND THE OVERHEAD POWER LINE RUNNING ACROSS REVISED TAX LOT 200 WILL HAVE A 10 FOOT UTILITY EASEMENT THE CENTERLINE OF WHICH IS THE CENTERLINE OF THE STRUCTURES. THE EASEMENT FOR THE SEPTIC TANK, DRAIN FIELD, AND WELL AND PUMP HOUSE WILL BE 5' OUTSIDE OF THOSE STRUCTURES. SEE SHARED WELL AND SEWER AGREEMENTS FILED SEPARATELY.

THIS SURVEY WAS CONDUCTED WITH A TOPCON HIPER + G.P.S. AND THE BEARINGS WERE ROTATED TO MY SURVEY CS#05-148-C.

REGISTERED
PROFESSIONAL
LAND SURVEYOR

J. Dennis Edwards

OREGON
JULY 16, 1971
G. DENNIS EDWARDS
9 5 1
RENEWS 12/31/2015

RECEIVED BY
Umatilla County Surveyor
Date: 3/24/2014
Rec'd By: G. Hensley
No.: 14-026-B

- LEGEND:**
- A ● FND. 5/8" IRON REBAR WITH PLASTIC CAP #951, MY CS #05-148-C
 - B ● FND. 5/8" IRON REBAR WITH PLASTIC CAP #951, MY CS #07-002-A
 - C ● FND. 5/8" IRON REBAR WITH PLASTIC CAP #1904, CHRISTENSON 1999 PLAT OF "VIEWCREST ADDITION"
 - SET 5/8"x24" OR 30" IRON REBAR WITH PLASTIC CAP #951
 - ⊗ SET CONC. NAIL WITH WASHER #951 UNLESS NOTED AS A SET P.K. NAIL
 - ⊙ COMPUTED LOCATION
 - ⊙ POWER POLE
 - (000) OF RECORD, MY CS #05-148-C
 - [000] OF RECORD, CHRISTENSON 1999 PLAT OF "VIEWCREST ADDITION"
 - OHP— OVERHEAD POWER LINE
 - SS— APPROX. LOC. OF SANITARY SEWER LINE & C/L OF 10' EASEMENT
 - W— APPROX. LOC. OF WATER LINE & C/L OF 10' EASEMENT

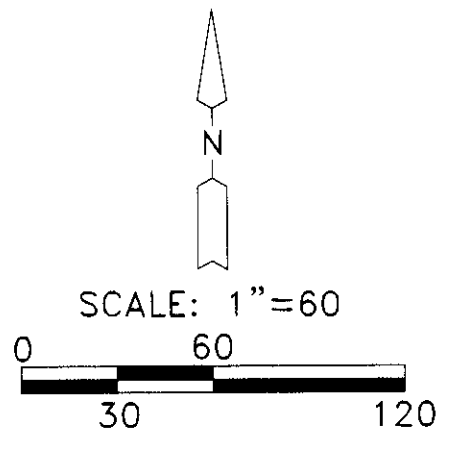

SURVEY FOR JUANITA ROSS
IN SW 1/4, SE 1/4 SEC. 9, T 4 N, R 28 E,
W.M., UMATILLA COUNTY, OREGON
02/18/2014 JOB# S1401007
EDWARDS SURVEYING P.O. BOX 763
541-567-3336 HERMISTON, OREGON 97838
DRAWN BY JMC