

NARRATIVE:

THE PURPOSE OF THIS SURVEY IS TO LOCATE THE CORNERS OF LOT 16 SO A HOME CAN BE SITED WITH THE PROPER SETBACKS.
 I RETRACED LAGIER'S PLAT OF "RIVER VIEW TERRACE" FROM MONUMENTS HE SET IN 1980 TO SET THE MISSING CORNERS. I ALSO TIED THE NORTHWEST CORNER OF LOT 19 TO CONFIRM THE LOCATION OF THESE CORNERS AND IT FIT VERY WELL.

REGISTERED
 PROFESSIONAL
 LAND SURVEYOR

G. Dennis Edwards

OREGON
 JULY 16, 1971
 G. DENNIS EDWARDS
 9 5 1
 RENEWS 12/31/2001

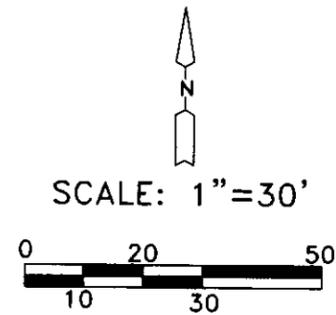

LEGEND:

- FND. 5/8" IRON REBAR PLAT OF "RIVER VIEW TERRACE SUBDIVISION"
- SET 5/8"x30" IRON REBAR WITH PLASTIC CAP #951

RECEIVED BY
 Umatilla County Surveyors
 Date 01-01
 Draw'n By NJF
 No. 01-08-A

SURVEY FOR BRAD LAWSON
 LOT 16, BLK. 2, "RIVER VIEW TERRACE SUBDIVISION",
 CITY OF UMATILLA, IN SE 1/4, SECTION 18, T 5 N,
 R 28 E, W.M., UMATILLA COUNTY, OREGON
 1/15/2001 JOB# S0101008
 EDWARDS SURVEYING P.O. BOX 763
 541-567-3336 HERMISTON, OREGON 97838
 DRAWN BY NJF

01-08-A